

## Metal halide uplighting for larger trees

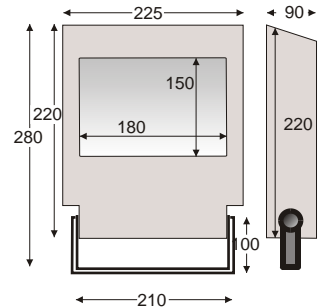

240v MH 70w 150w IP65

**Flood70** and **Flood150** symmetric metal halide floodlights are designed for lighting trees and facades from a remote position. The reflector is designed to project a wide 120° beam forwards to light a dense tree canopy or facade. **Wash70** and **Wash150** asymmetric metal halide floodlights are designed for lighting wide-spreading trees from beneath, “grazing” dense canopies such as large conifers from a close position or “wall washing” facades. The asymmetric reflector projects a wide 120° beam to light a tree or facade while still providing coverage at the base. It is intended for wide beam coverage of 2-3 storey facades and trees up to 30 metres. Wash and Flood models are fitted with an adjustable stirrup bracket for mounting on walls, concrete or the optional E9300 ground spike. Order lamps separately.



<b>E9322-70</b>	Flood70	70w	Symmetric beam
<b>E9322-150</b>	Flood150	150w	Symmetric beam
<b>E9323-70</b>	Wash 70	70w	Asymmetric beam
<b>E9323-150</b>	Wash150	150w	Asymmetric beam



**Spot70** and **Spot150** are surface-mount uplights with adjustable stirrup bracket for mounting on walls or the optional **E9300** 50cm ground spike. They are available in 70 watt and 150 watt versions using a double-ended metal halide lamp and polished reflector to project a 40° symmetric circular beam for uplighting larger trees. The cast aluminium body and stirrup bracket are powder coated in a matt dark grey finish which is discretely recessive in garden settings. Order lamp separately: **CDM-TD70** 70w or **CDMTD150** 150w.

<b>E9324-70</b>	Spot70	70w
<b>E9324-150</b>	Spot150	150w

240v MH 70w 150w IP66

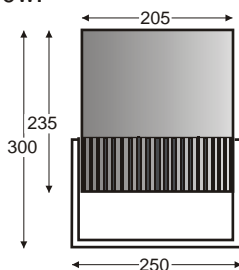

## Metal halide uplighting for larger trees



# Coolie 70

The new **E9012 Coolie70** recessed uplight provides both long lamp life and energy efficiency for lighting trees from lawns or paving. The **Coolie70** is a new-style recessed uplight providing a powerful 40° uplighting beam, using a double ended 70w metal halide lamp, while maintaining a typical top lens temperature of under 70°C - so **Coolie70** can be used even in walkover areas to uplight trees with an open canopy and branch structure from directly below.

Coolie70 has an upper compartment with a separate top lens insulated by an inner second lens from heat generated in the lower compartment which houses the lamp and control gear. **Coolie70** has a 316 stainless steel lens rim, a cast aluminium body and a polymer soil sleeve for recessing into the ground. (Provide 300mm depth of shingle drainage beneath the uplight: do not use in waterlogged ground). Order **CDM-TD70 lamp separately**.

**240v MH 70w IP67**



Coolie70 uplighting  
A large plum tree



**E9212 Coolie 35A** metal halide 35w recessed uplight has a 40° asymmetric beam @ 20° from vertical for lighting outer canopies of densely foliated trees and "washing" facades and conifer screens from lawns or paving. Cast-aluminium construction is combined with a plastic ground sleeve, stainless steel top plate around a cool lens suitable for walkover areas. (Provide 300mm depth of shingle drainage beneath the uplight: do not use in waterlogged ground). Order **CDM-T35 lamp separately**.

**240v MH 35w IP67**

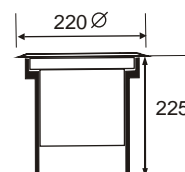
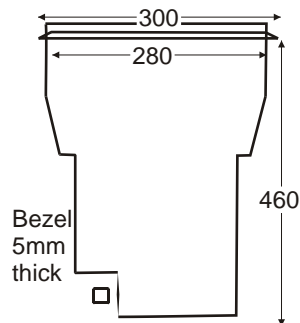

- 1 Where the shape of the tree falls within a 35-45° arc, use a single medium beam uplight such as *Spot* or *Coolie70*.
- 2 If the tree has a wider spread, especially over 10m, use 2 or more *Spot* or *Coolie70* uplights for a fuller effect.
- 3 Where the outer canopy is dense and the inner canopy & structure is more open, uplight the central trunk & branches with a medium beam *Spot* or *Coolie70* uplight and position *Wash* asymmetric floodlights or *Coolie35* recessed asymmetric uplights to illuminate the outer canopy.
- 4 When foliage is especially dense, as in conifers, and the feasible position of the light is just outside the canopy or you want to "graze" up the foliage surface to emphasise texture, you need a floodlight that will light the bottom of the canopy but "stretch" the light beam towards the top, which is what an asymmetric beam *Wash* or *Coolie35* will do.
- 5 Use a symmetric beam floodlight where the light stands back from the tree and is hidden behind a landscape feature.
- 6 Use more high power lights for dark foliage, eg copper beech.

## Lighting tips for larger trees

Part number	Tree height:	10 -15m	16 -20m	21 -25m	26 -30m
Symmetric beam uplights (for lighting from directly underneath)					
<b>E9012</b>	Coolie 70		*		
<b>E9324-70</b>	Spot70	*	*		
<b>E9324-150</b>	Spot150			*	*
Asymmetric beam uplights/floodlights (for lighting from just in front)					
<b>E9323-70</b>	Wash 70	*	*		
<b>E9323-150</b>	Wash150			*	*
<b>E9212</b>	Coolie 35A	*			
Symmetric floodlighting @ 45 degrees from horizontal					
<b>E9322-70</b>	Flood70	*			
<b>E9322-150</b>	Flood150		*	*	



Advice is for general guidance and subject to branch & canopy structure and foliage density, colour and translucence. Look up through the tree you propose to light - if you can see up through the branches, then light will penetrate the canopy and structure as well. If not, use floodlights or asymmetric uplights to light the tree externally. Lighting large trees is a black art: test the position of uplights with a temporary wiring set-up before final installation.